

UPQC

Universal Photonic Quantum Computer

In this project, QuiX Quantum is developing prototypes of an error-correctable universal photonic quantum computer and will deliver four hardware prototypes with up to 64 physical qubits to the DLR e.V. by 2026.

- Development of quantum computing algorithms
- Development of physical and algorithmic error correction methods
- Usable quantum computing hardware for DLR projects and others.

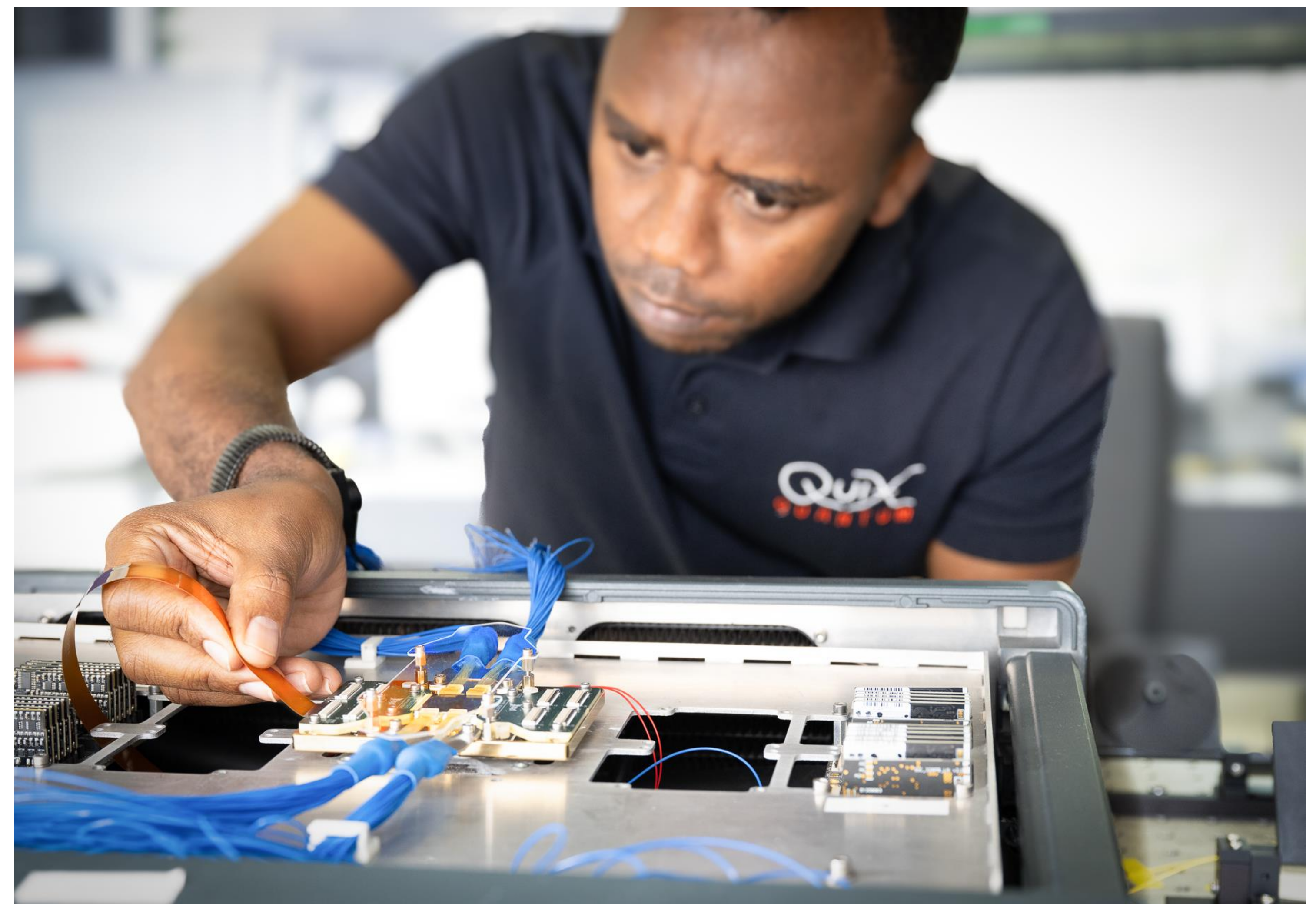

QuiX spent most of 2023/2024 on designing, manufacturing, and testing basic electronic and photonics components as well as laying the theoretical foundations for the design and architecture of an 8-qubit and a 64-qubit photonic quantum computer.

Alquor®: 12-Mode Special Purpose Quantum Computer

In August 2023 QuiX Quantum installed a 12-mode special purpose quantum computer at the DLR facility in Ulm, Germany and demonstrated the ability to execute gate operations in 2024.



Generation of heralded photons in SiN ring resonators

The most widely used single photons sources like ppKTP crystals or quantum dots are hard to scale beyond a few indistinguishable photons at a time.

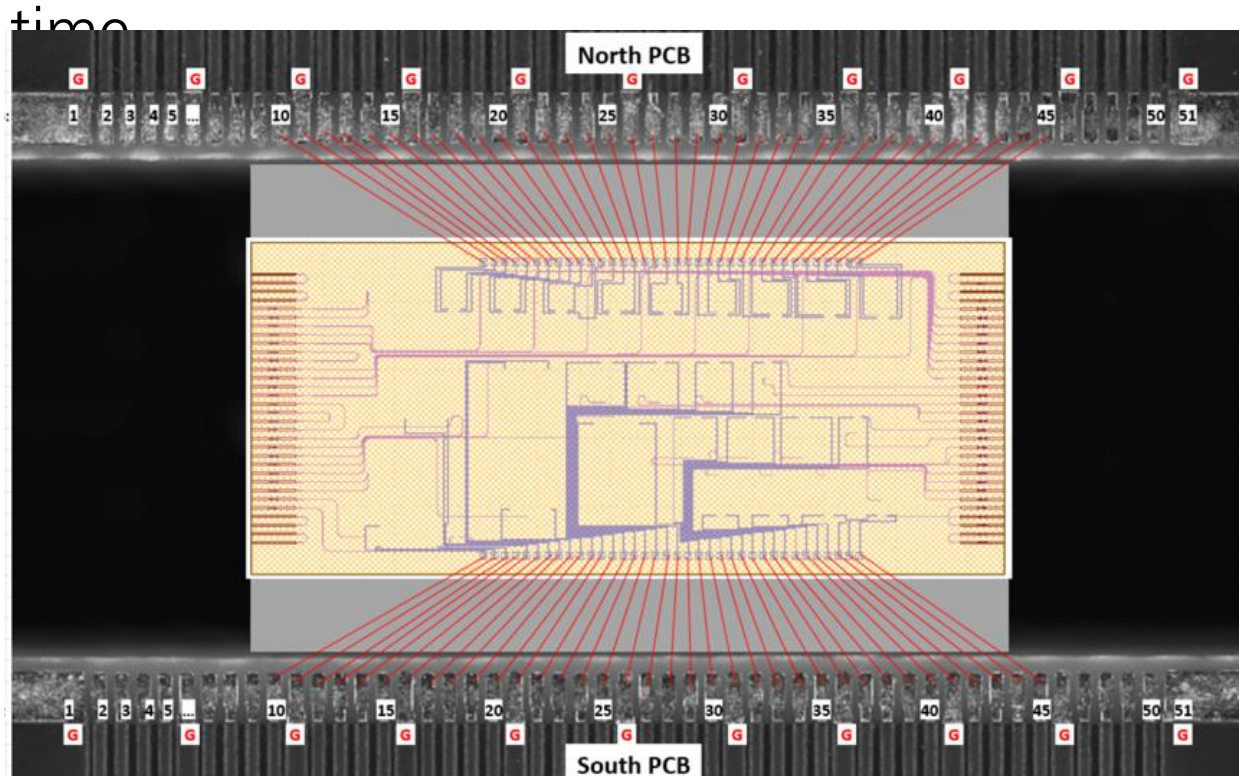

Therefore, QuiX decided to utilize spontaneous four wave mixing (SFWM) in SiN ring resonators which can be produced at wafer scale using CMOS processes. The first demonstration of heralded photon pairs was achieved in August 2024. A second processor with 64 photon generation rings was tested in 2025.

Chip-integrated pump-light filters with over 120dB

Using cascading CROW-filters in TriPlex® chips, QuiX demonstrated over 110dB of pump light attenuation in mid-2024.

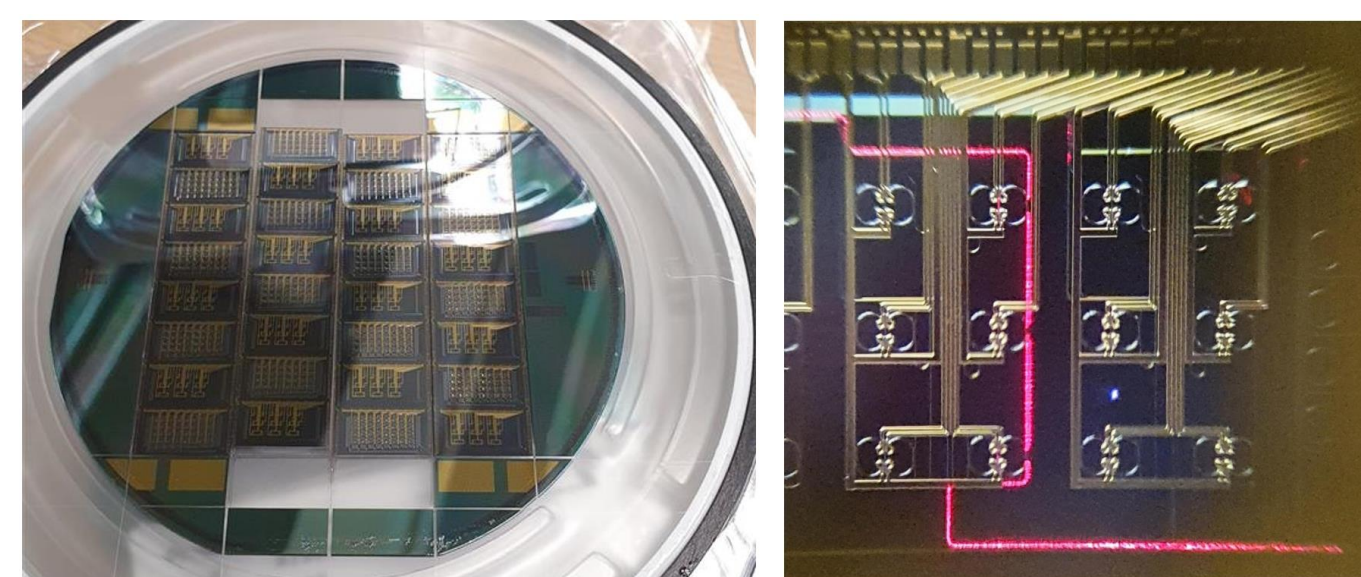

Chip-integrated delay lines with < 0.32 dB/m propagation loss

QuiX demonstrated chip-integrated delay lines of up to 2m length with propagation losses below 0.35dB/m in November 2023.

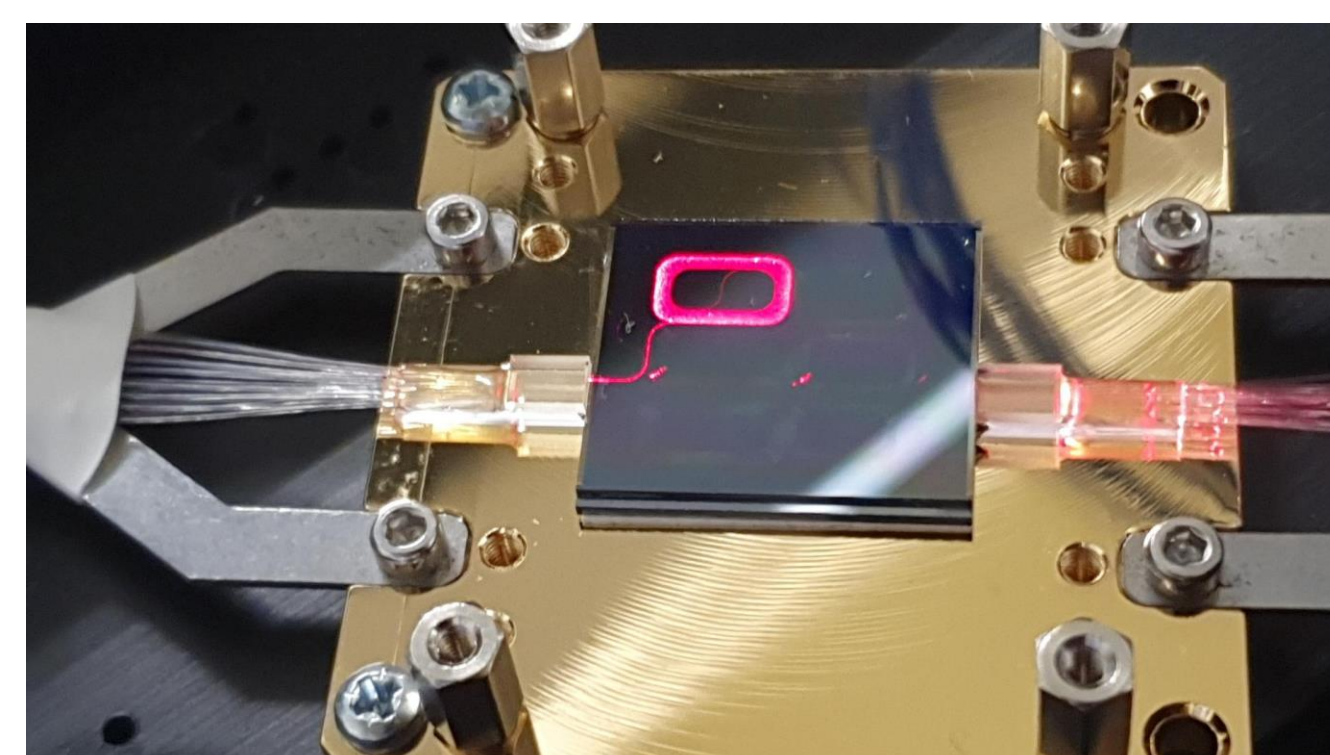

Fast phase shifters 10ns – 100ps

Fast phase shifters are essential to photonic quantum computing. QuiX and partner companies demonstrated that InP-based optical phase shifters can be switched in less than 10ns in November 2023 and pushed the performance to 100ps in early 2024.

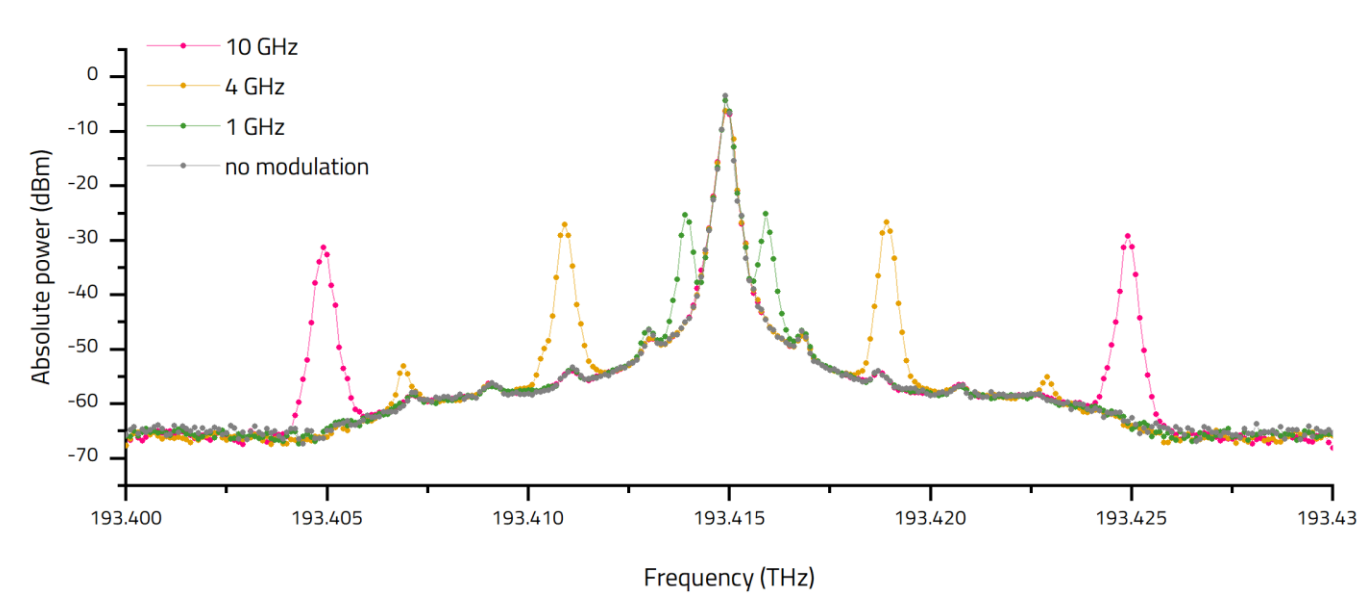

In 2025 QuiX also demonstrated phase shifters with switching speeds of up to 1 GHz on a SiN / LiNbO₃ hybrid photonic integrated circuit.

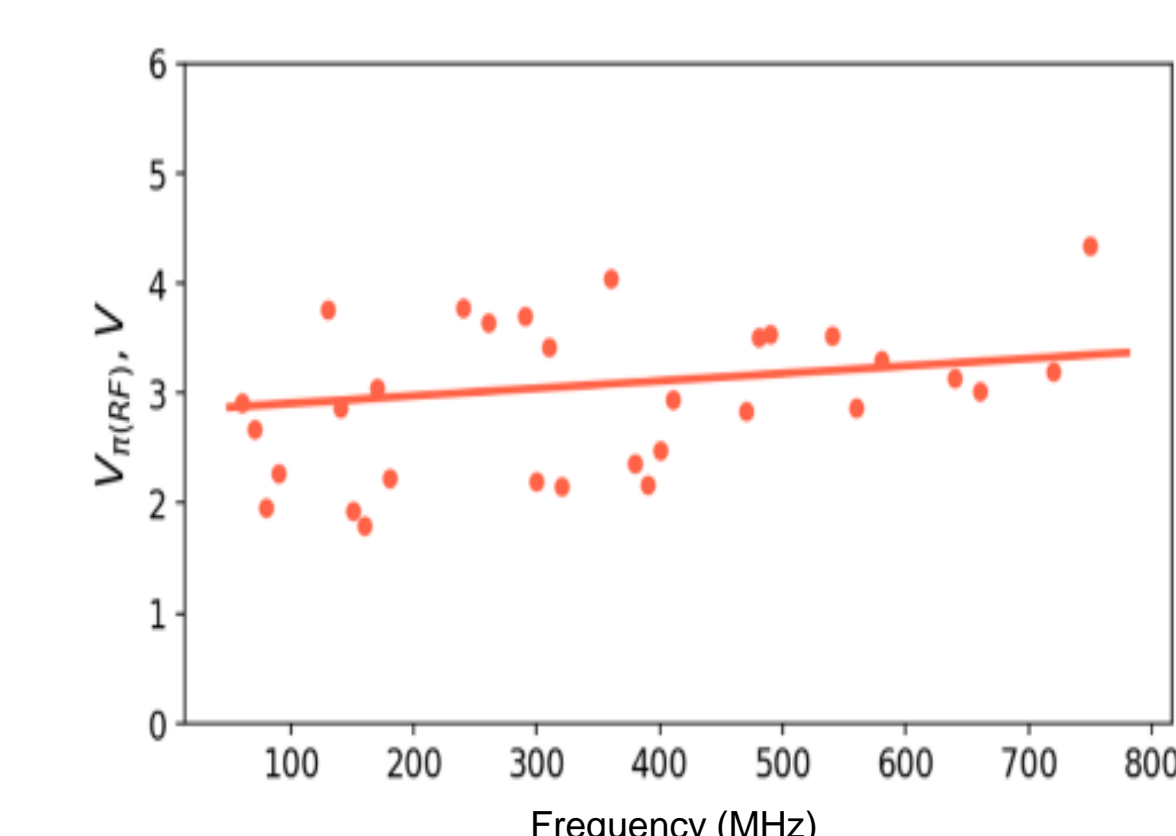

Superconducting Nanowire Single Photon Detectors (SNSPD)

Building quantum computers with hundreds or thousands of photonic qubits requires thousands of photon detectors. Since this is only achievable technically and economically with chip-level integration, QuiX and their partner Pixel Photonics have investigated, built, and demonstrated multiple world-first technologies including:

Chip-integrated SNSPD on TriPlex® (SiN)

Scaling a photonics quantum computer to thousands of qubits requires thousands of photon detectors. For cost and scalability reasons, chip integration of the detectors is therefore essential for a future upgrade to UPQC with thousands of qubits. To address this challenge, Pixel Photonics and QuiX Quantum designed and produced the world's first chip-integrated SNSPDs on the TriPlex® SiN platform.

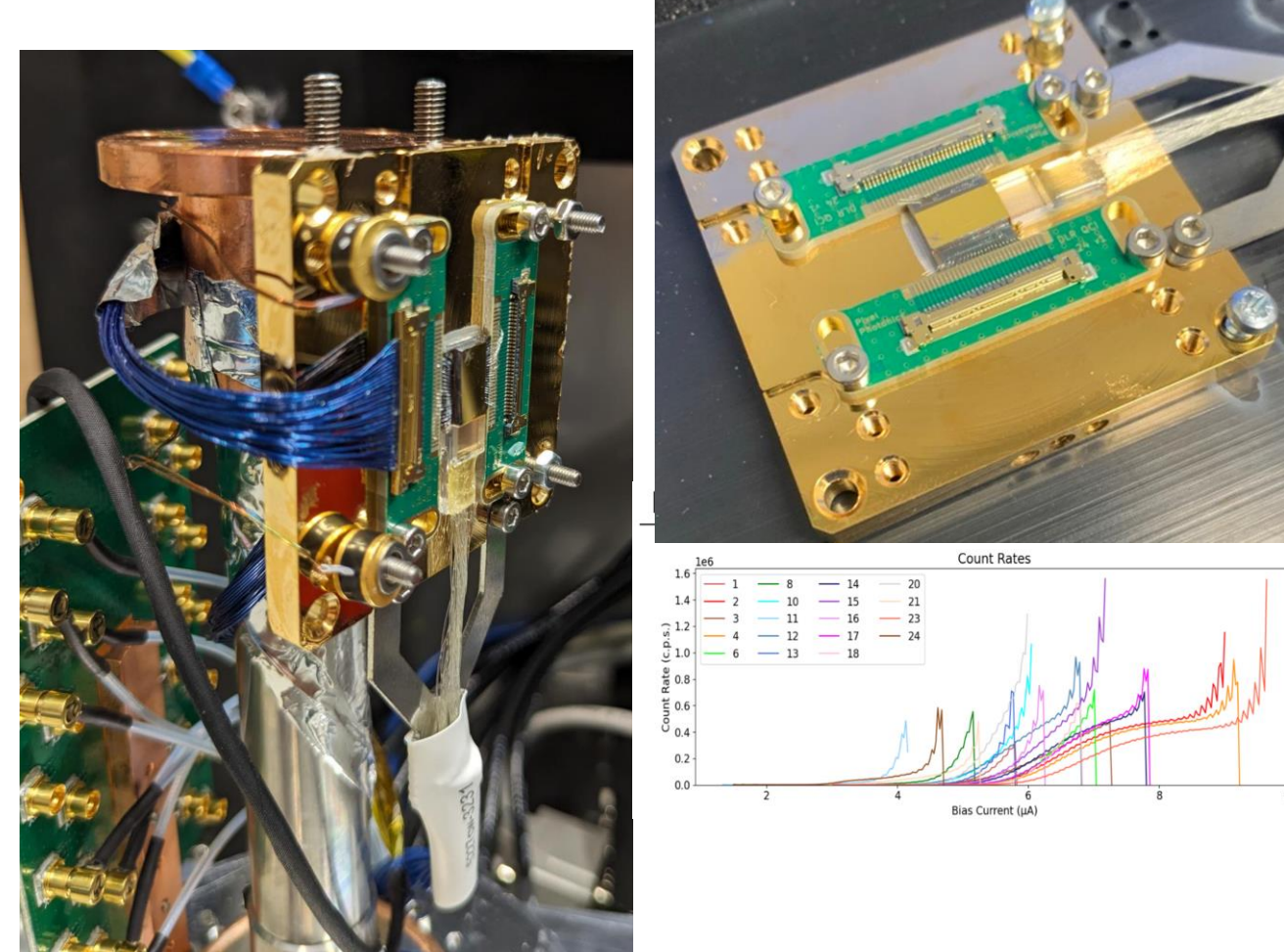

16 channel row-column multiplexed SNSPD

One of the biggest issues in quantum computing is the required cooling to cryogenic temperatures. While photonic quantum computing has the advantage that most components can operate at room temperature, photon detectors still need to be operated at ~3K.

One of the biggest obstacles to efficient cooling is the heat transfer along electric wiring for the readout electronics. Using row-column multiplexing, n² single photon detectors can be read with only 2n electrical connection, greatly lowering cooling requirements.

This scheme had so far only been demonstrated using free-space setups. QuiX and Pixel Photonics demonstrated the first chip-integrated 16 channel row-column multiplexed SNSPD.

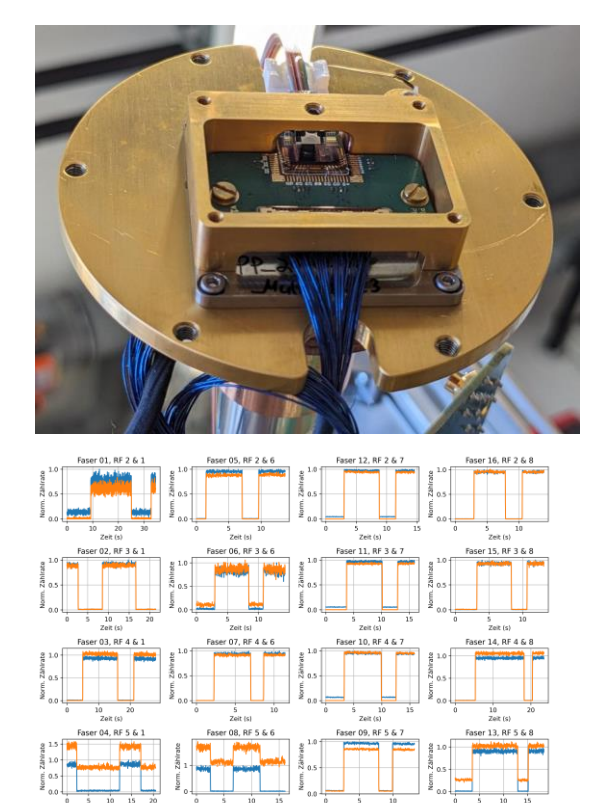

Carina® -- Universal Photonic Quantum Computation with Graph States

QuiX Quantum is in the process of assembling Carina, an 8 qubit universal photonic quantum computing demonstrator using 4 qubit graph states as its computational base.

- First universal photonic quantum computer
- Power usage < 3500 W
- Chip-integrated photon sources, multiplexer, and state generator
- Multiplexed generation of 8 simultaneous input photons
- 4 qubit resource state generated out of 8 input qubits
- 10 MHz clock cycle
- Optimized gate-based to MBQC compiler
- Up to more than 10 gate operations per clock cycle with optimization.
- Examples for Shor, Deutch, Grover, Teleportation algorithms



Carina Emulator

The Carina Emulator represents a digital twin of the Carina hardware with simulation of all qubit and photonic operations supported by the Carina hardware. Additionally it supports compilation and optimization of gate-based quantum circuits to measurement-based quantum computing operations.

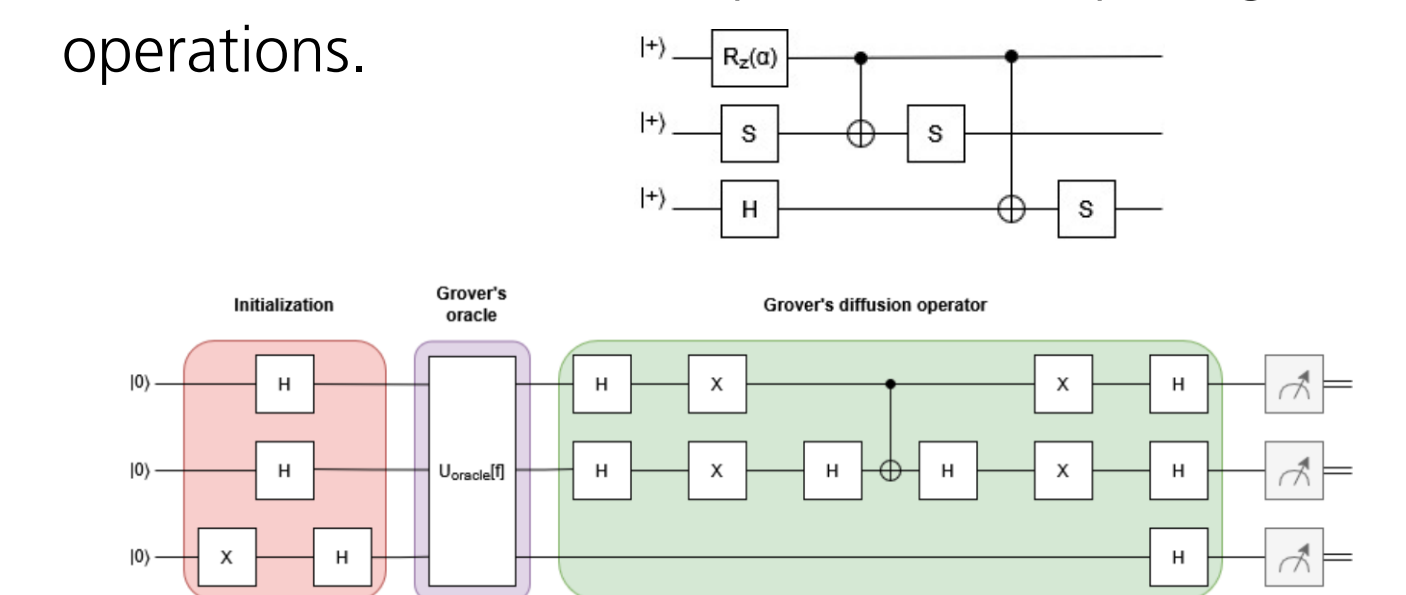

More information about the project on <https://qci.dlr.de/en/upqc/>

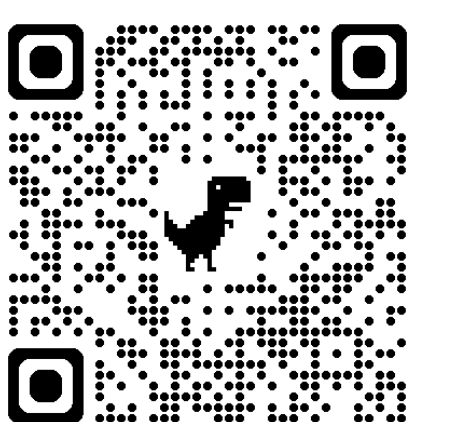

A project of



Contractor



Contact

Lars Hohmuth
QuiX Quantum GmbH
l.hohmuth@quixquantum.com



Supported by:



on the basis of a decision by the German Bundestag